

Manual cutting and welding table

Operating instructions EX-0-922-005

Edition 1, 2024-08-06

THERMACUT[®]
THE CUTTING COMPANY[®]

Table of contents

1 Identification	3
1.1 Signs and symbols used	3
1.2 Classification of the warnings	3
1.3 Product label	4
2 Safety	5
2.1 Intended Use	5
2.2 Responsibilities of the Operator	5
2.3 Warnings and Information Signs	6
2.4 Safety Instructions	7
2.4.1 Basic safety instructions	7
2.4.2 Safety instructions for welding and cutting	7
2.4.3 Safety instructions for personal protective equipment	7
2.4.4 Safety instructions for cutting and welding fumes and dust	8
2.4.5 Safety instructions for emergencies	8
3 Scope of Delivery	8
4 Product Description	9
4.1 Structure and Function	9
5 Technical data	10
5.1 Ambient conditions	10
5.2 Product Data	10
6 Transport and Setup	11
6.1 Transporting the Product	12
7 Putting Into Operation	12
7.1 Fitting Piping	13
7.2 Establishing Potential Equalization	14
8 Operation	15
9 Putting Out of Operation	15
10 Maintenance and Cleaning	16
10.1 Maintenance and Cleaning Intervals	17
10.2 Cleaning the Cutting Grid and Interior	17
10.3 Emptying and Cleaning the Dust Collecting Container	19
11 Faults and their Correction	21
12 Disassembly	22
13 Disposal	23
13.1 Disposing of Cutting and Welding Dust	23
13.2 Disposal of materials	23
13.3 Disposal of consumables	23
13.4 Disposing of packaging	23
14 Addresses and contacts	24

1 Identification

These operating instructions describe the manual cutting and welding table. When used in these operating instructions, the term "product" always refers to the manual cutting and welding table.

The product is a stationary solution for extracting fumes and dust that result from the welding, cutting and grinding processes.

1.1 Signs and symbols used

In these operating instructions, the following signs and symbols are used:

▶	General instructions.
1.	Steps to be carried out in succession.
-	Lists.
⇒	The cross-reference refers to detailed, supplementary or further information.
A	Caption, item description.

1.2 Classification of the warnings

The warning notices used are divided into four different levels and are printed in front of potentially dangerous work steps.

1 Identification

Depending on the type of danger, the following signal words are used:

 DANGER	
	Describes an imminent danger. Will result in death or serious injuries if not avoided.
 WARNING	
	Describes a potentially dangerous situation. May result in death or serious injuries if not avoided.
 CAUTION	
	Describes a potentially damaging situation. May result in slight or minor injuries if not avoided.
NOTE	
	Describes possible property damage. If the notice is not followed, irreparable damage to the product or equipment can be the result. Work results may be impaired.

1.3 Product label

This product fulfills the requirements that apply to the market to which it has been introduced. A corresponding marking has been affixed to the product, if required.

2 Safety

This chapter describes the essential safety requirements and warns of residual hazards that should be kept in mind, to keep the product safely. Non-observance of the safety instructions may result in risks to the life and health of personnel as well as cause environmental or material damage.

2.1 Intended Use

The product is used for the extraction of cutting and welding fumes and dust. The product can be used with filter systems for extraction and filtering during the cutting and welding of steels with a nickel and chrome alloy content of less than 30 %.

The product may only be used for the purpose and in the way described in this document. Any other use is considered non-intended. Unauthorized conversion work or modifications to increase performance are not permissible.

- ▶ Only operate the product with original THERMACUT spare parts.
- ▶ Do not exceed the maximum load data given in the documents. Excess loads will lead to irreparable damage.
- ▶ Do not make any structural modifications to the product.
- ▶ Use the product only in a closed environment.
- ▶ Do not use or store the product in wet conditions.
- ▶ Only store the product outdoors when sufficiently protected against the influences of the weather.

2.2 Responsibilities of the Operator

- ▶ Keep non-suitably qualified people out of the work area.
- ▶ Ensure that only suitably qualified personnel perform work on the product or system.

Suitably qualified personnel are:

- those who are familiar with the basic regulations on occupational safety and accident prevention;
- those who have been instructed on how to handle the product;
- those who have read and understood all related documentation;
- those who have been trained accordingly;
- those who are able to recognize possible risks because of their special training, knowledge, and experience.

2.3 Warnings and Information Signs

The following warning, notice and mandatory signs can be found on the product.

These markings must always be legible. They may not be covered, obscured, painted over, or removed.

	<p>► Wear a respiratory mask.</p>
	<p>► Wear a protective suit.</p>
	<p>► Wear protective gloves.</p>
	<p>► Wear safety goggles.</p>
	<p>► Read and follow the operating manual.</p>
	<p>► Do not throw any cigarettes or burning objects into the product.</p>
	<p>Warning against hot surfaces. Risk of burns.</p> <p>► Do not touch hot surfaces.</p>
	<p>Beware of slipping hazard.</p> <p>► Ensure a dry and clean base at the setup location.</p>

2.4 Safety Instructions

2.4.1 Basic safety instructions

The product has been developed and manufactured in accordance with the latest technology and recognized safety standards and directives. Due to the product design, unavoidable technical residual risks exist to the user, third parties, devices, and other material property. The manufacturer will accept no liability for damage caused by non-observance of the documentation.

- ▶ Please read the documentation carefully before using the product for the first time and comply with the instructions contained.
- ▶ Only operate the product in technically perfect condition and ensure compliance with all documentation.
- ▶ Read the documentation carefully before carrying out specific work, for example, commissioning, operation, transport, and maintenance.
- ▶ Use suitable means to protect yourself and bystanders from the hazards listed in the documentation.
- ▶ Store the documentation within easy reach of the product for reference and enclose all documents when passing on the product.
- ▶ Consult the documentation for the other components used.
- ▶ Observe the local accident prevention regulations.
- ▶ Only trained specialists should commission, operate, and service the device. Qualified personnel are persons who, based on their special training, knowledge, experience and due to their knowledge of the relevant standards, are able to assess the tasks assigned to them and identify possible dangers.
- ▶ Ensure the work area is well lit and keep it neat and tidy.
- ▶ For disposal, observe the local regulations, laws, provisions, standards, and directives.

2.4.2 Safety instructions for welding and cutting

- ▶ Arc welding and thermal cutting can damage eyes, skin, and hearing. Note that further hazards can occur in connection with other components. For this reason, always wear the mandatory protective clothing in accordance with local laws and directives.
- ▶ All metal vapors, especially lead, cadmium, copper and beryllium, are harmful. Ensure sufficient ventilation or extraction. Do not exceed the established workplace exposure limits (WEL).
- ▶ To prevent phosgene gas from forming, always use clear water to rinse workpieces that have been degreased using chlorinated solvents. Do not place degreasing baths containing chlorine in the vicinity of the welding, or cutting work area.
- ▶ Adhere to the general fire protection regulations and remove flammable materials from the vicinity of the welding or cutting work area prior to starting work. Provide suitable fire extinguishing equipment in the work area.

2.4.3 Safety instructions for personal protective equipment

- ▶ Do not wear any loose clothing or jewelry.
- ▶ Wear a hairnet over long hair.
- ▶ Note local laws and directives concerning protective equipment.
- ▶ Make sure that any third parties in the direct vicinity are wearing personal protective equipment.
- ▶ Wear your personal protective equipment according to the hazard.

2.4.4 Safety instructions for cutting and welding fumes and dust

The cutting or welding process produces fumes containing harmful dust particles which can settle on surfaces and get into the ambient air. They can damage the respiratory system when inhaled.

- ▶ Check and wear your personal protective equipment.
- ▶ Only use the product in rooms which are sufficiently ventilated.
- ▶ Make sure that all the seals on the product are free of dirt.
- ▶ Remove dust deposits in the surrounding area immediately using an industrial vacuum cleaner of dust class H or a damp cloth.
- ▶ The filtration system provided must be used when operating the product.

The extraction of substances and materials which are combustible, aggressive, chemical or contain oil vapors as well as aluminum or magnesium dusts can lead to fire and explosion due to chemical reactions. Serious injuries and irreparable damage to the product can be the result.

- ▶ Only ever use the product as intended.
- ▶ Use a suitable filter system.

2.4.5 Safety instructions for emergencies

- ▶ In an emergency, immediately disconnect all supplies (e.g. electrical power supply, coolant supply, compressed air supply, shielding gas supply).
- ▶ Extinguish burning oil or emulsions using a CO₂ or powder fire extinguisher.

3 Scope of Delivery

The following components are included in the scope of delivery:

- 1 × Manual cutting and welding table
- 1 × Operating instructions
- ▶ Order the equipment parts and wear parts separately.
- ▶ The order data for the equipment parts and wear parts can be found in the current order documents.
- ▶ For more information about points of contact, consultation, and orders, visit www.thermacut.com.

Although the items delivered are carefully checked and packaged before dispatch, it is not possible to fully exclude the risk of transport damage.

Goods-in inspection

- ▶ Use the delivery note to check that everything has been delivered.
- ▶ Check the delivery for damage (visual inspection).

Complaints

- ▶ If goods are damaged, contact the final carrier.
- ▶ Keep the packaging for a possible check by the carrier.

Returns

- ▶ Use the original packaging and packing material for returns.
- ▶ If you have questions concerning packaging and safety during shipment, contact your supplier, carrier, or transport company.

4 Product Description

4.1 Structure and Function

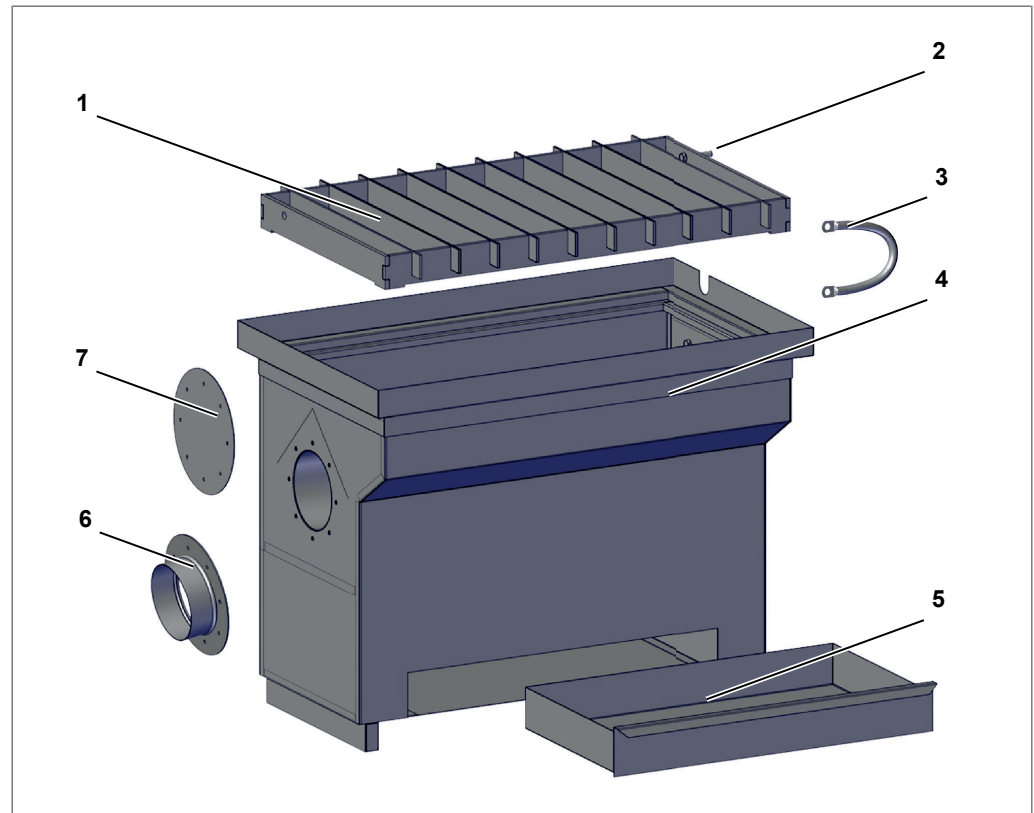

Figure 1 Structure and Function

1	Cutting grid	2	Connection bolt for potential equalization
3	Potential equalizing cable	4	Table housing
5	Dust collecting container	6	Connection piece
7	Cover plate		

During thermal welding and cutting processes, fumes and dust that are hazardous to health are produced, and these can be extracted and collected by the table and a connected filter system.

Fumes and dust are collected and drawn off directly via the cutting grid. During welding or cutting, coarse dust and slag particles fall downwards and are collected in a pull-out dust collecting container.

The following filter systems can be connected to the product:

- HERR filter system, e.g. 880200-40

5 Technical data

5.1 Ambient conditions

Temperature of the ambient air	-10 °C to +40 °C
Relative air humidity	80% non-condensing

Table 1 Ambient conditions for transport and storage

Temperature of the ambient air	+10 °C to +40 °C
Relative air humidity	70% non-condensing

Table 2 Ambient conditions for operation

5.2 Product Data

	EX-0-716-030	EX-0-716-031	EX-0-716-032
Dimensions (L × W × H)	800 × 600 × 800 mm	1200 × 600 × 800 mm	1200 × 800 × 800 mm
Max. cutting area	700 × 500 mm	1100 × 500 mm	1100 × 700 mm
Weight	90 kg	117 kg	132 kg
Capacity of dust collecting container	20 l	27 l	40 l
Nominal diameter for DN intake piping	Ø 160 mm		
Air volume required	2000 m ³ /h	2200 m ³ /h	2500 m ³ /h
Dimensions of individual cutting grid bars (L × W × H)	593 × 50 × 5 mm		793 × 50 × 5 mm
Max. load	350 kg with even load per area unit		

Table 3 Product data

6 Transport and Setup

 **WARNING****Risk of injury due to improper transport and setup**

Improper transport and setup can cause the product to topple or fall over. Serious injuries can be the result.

- ▶ Check and wear your personal protective equipment.
- ▶ Place the product on a suitable base (flat, solid, dry) on which it will not topple over.
- ▶ Take the weight of the product into account when lifting it. ⇒ 5 *Technical data* (Page 10)
- ▶ Use an appropriate lifting tool with load handling attachment for transport and setup of the product.
- ▶ Avoid jerky lifting and set-down of the product.
- ▶ Do not lift the product over persons or other units.
- ▶ At least two fitters should transport and set the product up.

NOTE**Property damage due to improper transport and setup**

Improper transport or setup can cause the product to topple or fall over. This can result in material damage and irreparable damage to the product.

- ▶ Protect the product against weather conditions, such as rain and direct sunlight.
- ▶ Ensure that the product does not make contact if you pass over edges.
- ▶ Use the product only in dry, clean and well-ventilated rooms.
- ▶ Maintain a minimum distance of 1 m from the wall when setting the product up in order to ensure that the product has sufficient ventilation.
- ▶ At least two fitters should transport and set the product up.

NOTE**Material damage due to forklifts/pallet trucks driving under the product improperly**

If the forklift/pallet truck drives too far under the product, it can be damaged.

- ▶ Drive under the product carefully and only until the forklift/pallet truck cannot go any further.

NOTE**Material damage due to unsuitable means of transport**

If an unsuitable vehicle is used to drive under the product, the product and dust collecting container can become damaged.

- ▶ Use a suitable forklift truck with a fork width of max. 50 mm.
- ▶ Take the low base height of the product into account.

6.1 Transporting the Product

1. Drive a forklift with suitable fork length completely under the product.
2. Transport to a suitable setup location and set down.

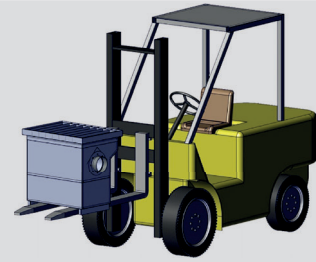

7 Putting Into Operation

WARNING



Fire hazard due to improper use

Improper use of the product can cause a fire. Serious burns can be the result.

- ▶ Do not use the product in areas subject to dust or gas explosion hazards.
- ▶ Do not use the product to extract fumes that result from cutting or welding oil-wetted parts.
- ▶ Do not use the product to extract flammable substances and liquids.

7.1 Fitting Piping

The filter system can be attached to the connection piece using piping (not included in the scope of delivery).

Depending on requirements, the connection piece can be mounted on the right- or left-hand side of the product. To guarantee optimum extraction, the other side always has to be closed using a cover plate.

1. Use suitable fasteners to attach the filter system to the connection piece on the product and seal using sealing tape.

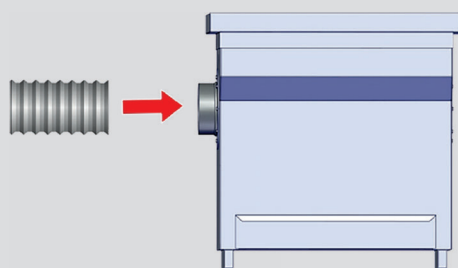

Swapping the connection piece and cover plate (optional)

1. Undo the screws on the connection piece and take the connection piece off.

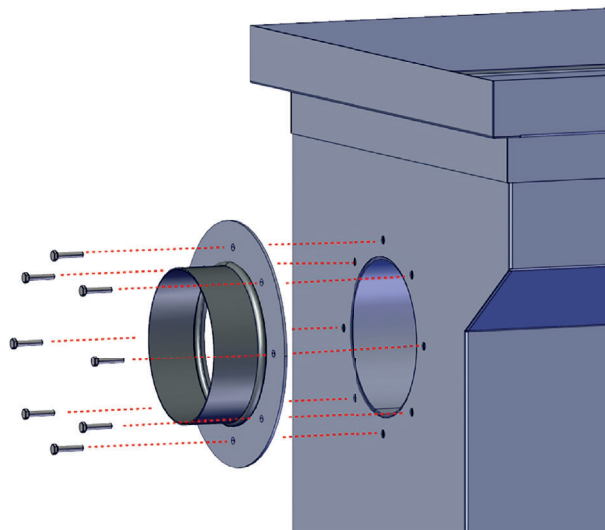

2. Undo the screws on the cover plate take the cover plate off.

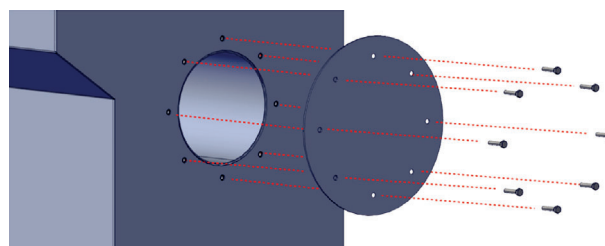

3. Attach the connection piece and the cover plate on the respectively opposite side.

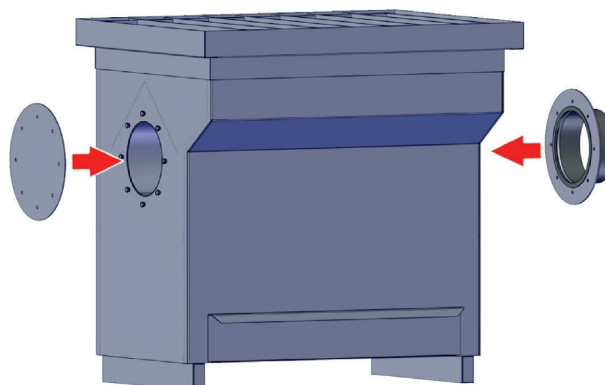

7.2 Establishing Potential Equalization

WARNING



Electric shock due to damaged or improperly installed cable

The use of damaged or improperly installed cables may result in a potentially fatal electric shock.

- ▶ Check all live cables and connections for proper installation and damage.
- ▶ Have any damaged, deformed, or worn parts replaced by a qualified electrician only.

To protect electronic components against negative impact due to electric interference currents, potential equalization must be established at the product and at the cutting surfaces. We recommend using a 70 mm² grounding cable to ground the product.

1. Undo the M12 nut on the upper connection bolt using a size 19 socket wrench and take it off.

2. Remove the split washer and washers.

3. Position the potential equalization cable on the upper connection bolt.

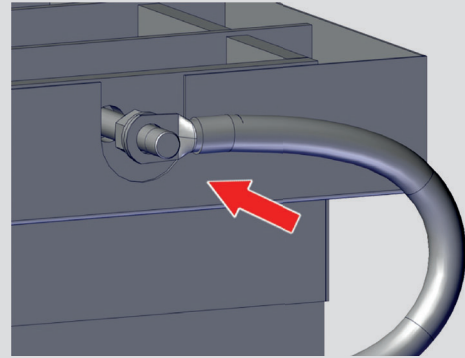

4. Fit the washers, the split washer and the nut using a size 19 socket wrench.

5. Undo the M12 nut on the lower connection bolt using a size 19 socket wrench and take it off.

6. Remove the split washer and washers.

7. Position the potential equalization cable on the lower connection bolt.

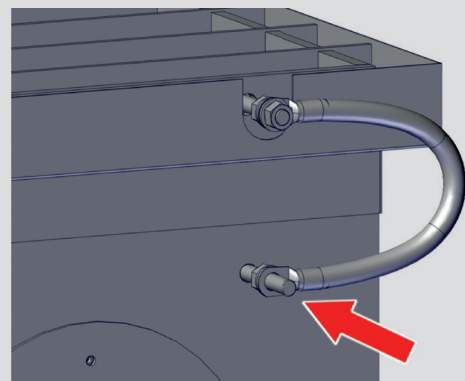

8. Position a further potential equalization cable (provided by the customer, not included in the scope of delivery) for potential equalization to the building on the lower connection bolt.

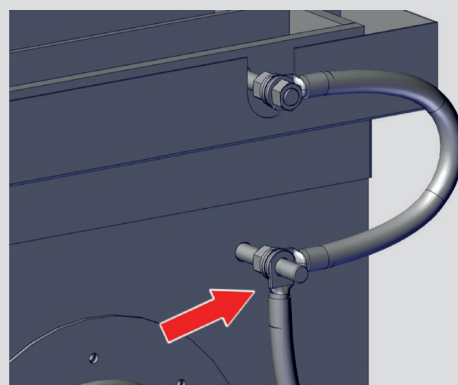

9. Fit the washers, the split washer and the nut using a size 19 socket wrench.

10. Establish potential equalization to the building using the potential equalization cable provided by the customer.

8 Operation

WARNING



Health risk through inhalation of harmful cutting and welding fumes and dust

The cutting and welding process produces fumes containing harmful dust particles which can settle on surfaces and get into the ambient air. They can damage the respiratory system when inhaled.

- ▶ Check and wear your personal protective equipment.
- ▶ Only use the product in rooms which are sufficiently ventilated.
- ▶ Make sure that all the seals on the product are free of dirt.
- ▶ Remove dust deposits in the surrounding area immediately using an industrial vacuum cleaner of dust class H or a damp cloth.

WARNING



Fire hazard due to improper use

Improper use of the product can cause a fire. Serious burns can be the result.

- ▶ Do not use the product in areas subject to dust or gas explosion hazards.
- ▶ Do not use the product to extract fumes that result from cutting or welding oil-wetted parts.
- ▶ Do not use the product to extract flammable substances and liquids.

- ▶ Switch on the connected filter system.
- ▶ Consult the documentation of all components used.

9 Putting Out of Operation

- ▶ Switch off the connected filter system.

10 Maintenance and Cleaning

Regular maintenance and cleaning are prerequisites for a long service life and perfect function. The maintenance interval is determined by the working environment and operating time of the products. If the product is operated for longer than 8 hours per day, the maintenance interval should be adapted according to requirements.

WARNING



Health risk through inhalation of harmful cutting and welding fumes and dust

The cutting and welding process produces fumes containing harmful dust particles which can settle on surfaces and get into the ambient air. They can damage the respiratory system when inhaled.

- ▶ Check and wear your personal protective equipment.
- ▶ Only use the product in rooms which are sufficiently ventilated.
- ▶ Make sure that all the seals on the product are free of dirt.
- ▶ After cleaning and maintenance work check all screwed joints for a tight fit, leaks, chafing points. Tighten any loosened screwed joints. Correct any faults found immediately.
- ▶ Remove dust deposits in the surrounding area immediately using an industrial vacuum cleaner of dust class H or a damp cloth.

WARNING



Risk of burns due to hot surfaces and glowing slag

Glowing slag is produced during cutting and welding processes. The surface of the product can become very hot. This poses a risk of burns.

- ▶ Allow the product to cool before carrying out maintenance and cleaning work.
- ▶ Check and wear your personal protective equipment.

WARNING



Risk of crushing

Limbs can be crushed if product components are improperly installed or uninstalled.

- ▶ Do not reach into the danger zone.
- ▶ Check and wear your personal protective equipment.

- ▶ Consult the documentation of all components used.

10.1 Maintenance and Cleaning Intervals

The given intervals are for guidance and refer to one-shift operation. We recommend documenting the checks. At least the test date, the defects found and the name of the tester should be documented.

Interval	Job
If necessary	<ul style="list-style-type: none"> ▶ Check the fill level in the dust collecting container and empty if necessary. ⇒ 10.3 <i>Emptying and Cleaning the Dust Collecting Container (Page 19)</i>
Weekly	<ul style="list-style-type: none"> ▶ Check the product for outer signs of damage. ▶ Check the potential equalization cable, connection hoses and connections for a tight fit and damage, replace if necessary. ▶ Check all connection points of the piping, the connection piece and the cover plate for escaping dust.
Yearly	<ul style="list-style-type: none"> ▶ Check the ground connections of the product and filter system for damage. ▶ If installed, open the piping inspection flap, and check the piping for dust deposits.

10.2 Cleaning the Cutting Grid and Interior

 **WARNING**

	<p>Risk of injury due to sharp edges</p> <p>The edges of the cutting grid are very sharp. Cutting injuries can be the result.</p> <ul style="list-style-type: none"> ▶ Wear protective gloves. ▶ Use at least 2 people for removal and insertion of the cutting grid.
---	--

To extract swirling dust particles directly, the connected filter system should be switched on during cleaning of the cutting grid.

1. Switch on the connected filter system.

2. Clean the cutting grid with a hand brush.

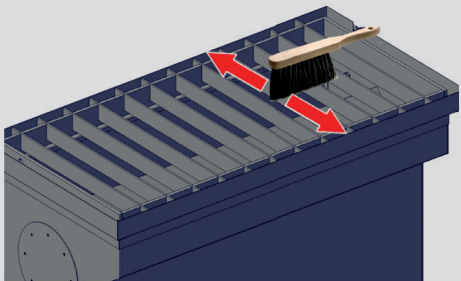

3. Switch off the connected filter system.

4. Remove both potential equalization cables.
⇒ 7.2 *Establishing Potential Equalization*
(Page 14)

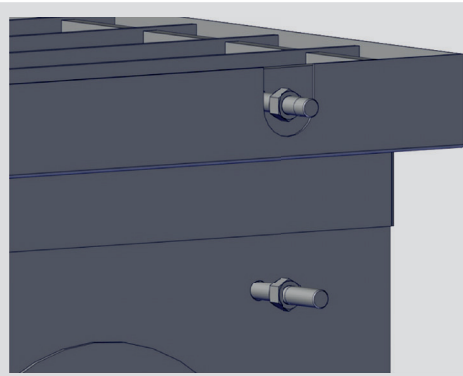

5. Have 2 people carefully lift and remove the cutting grid.

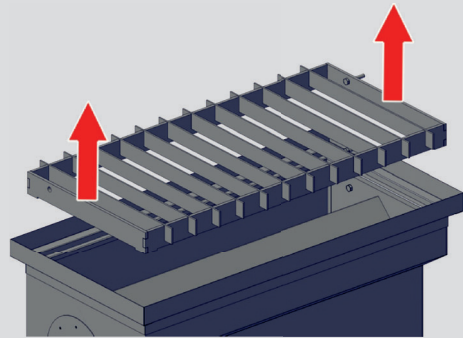

6. Vacuum out the interior of the product using an industrial vacuum cleaner of dust class H.

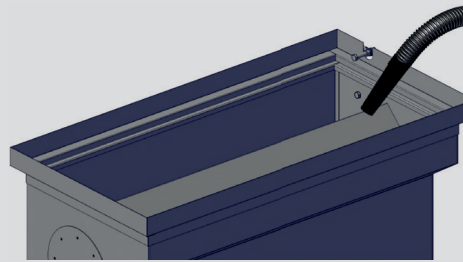

7. Have 2 people carefully take hold of and insert the cutting grid.

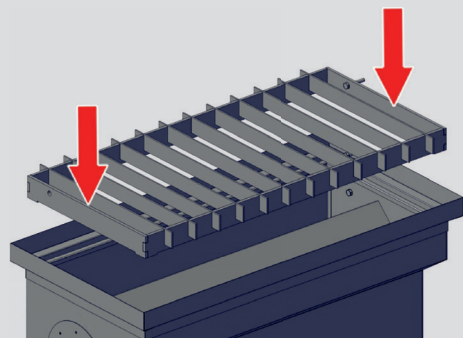

8. Attach both potential equalization cables.
⇒ 7.2 *Establishing Potential Equalization*
(Page 14)

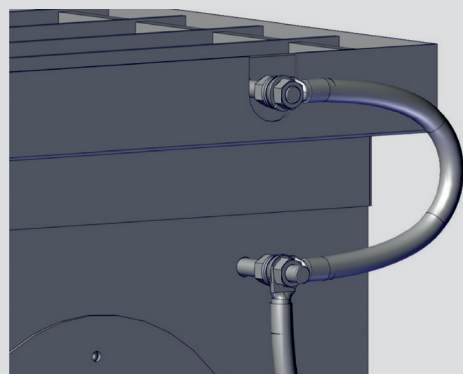

10.3 Emptying and Cleaning the Dust Collecting Container

1. Remove both potential equalization cables.
⇒ 7.2 *Establishing Potential Equalization*
(Page 14)

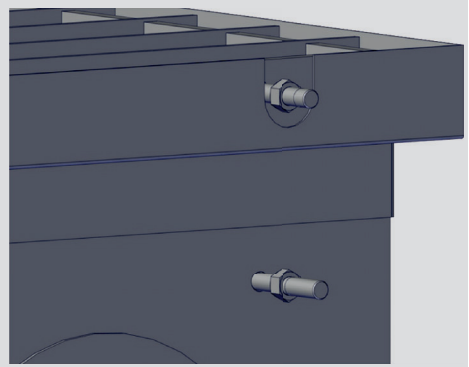

2. Pull the dust collecting container out.

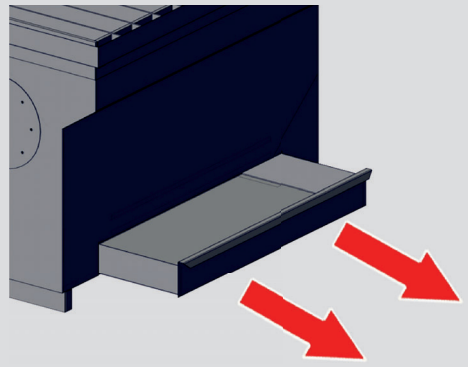

3. Empty the dust collecting container.

4. If heavily soiled, vacuum out the dust collecting container and the slide-in compartment using an industrial vacuum cleaner of dust class H.

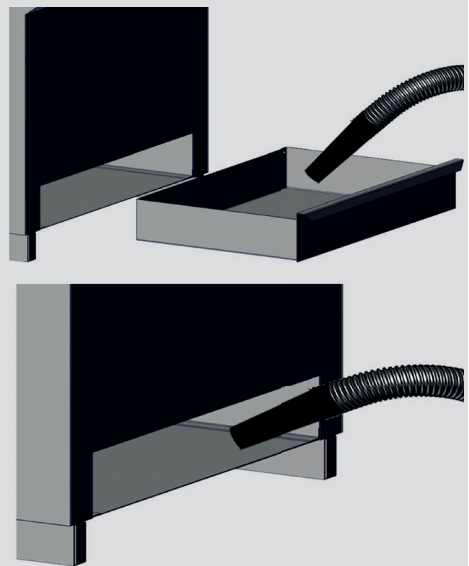

5. Dispose of the dust and slag in accordance with local laws and directives. ⇒ 13
Disposal (Page 23)

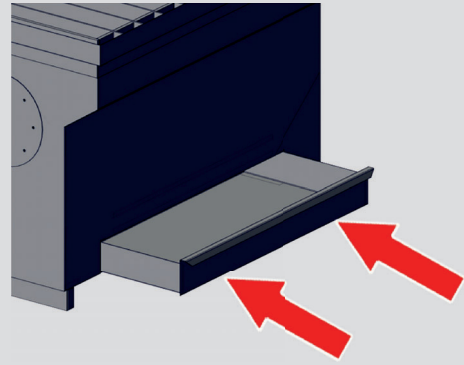

6. Insert the dust collecting container.

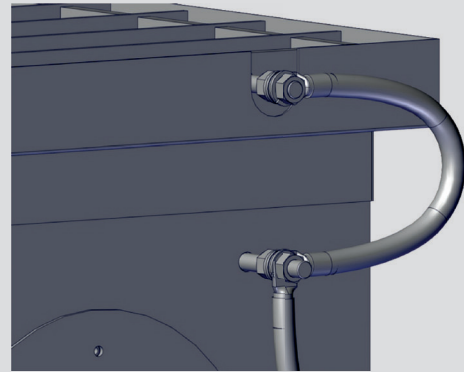

7. Attach both potential equalization cables.
⇒ 7.2 *Establishing Potential Equalization*
(Page 14)



11 Faults and their Correction

 WARNING	
	<p>Health risk through inhalation of harmful cutting and welding fumes and dust</p> <p>The cutting and welding process produces fumes containing harmful dust particles which can settle on surfaces and get into the ambient air. They can damage the respiratory system when inhaled.</p> <ul style="list-style-type: none"> ▶ Check and wear your personal protective equipment. ▶ Only use the product in rooms which are sufficiently ventilated. ▶ Make sure that all the seals on the product are free of dirt. ▶ Remove dust deposits in the surrounding area immediately using an industrial vacuum cleaner of dust class H or a damp cloth.

- ▶ Consult the documentation of all components used.
- ▶ Contact your retailer or THERMACUT in the event of questions or problems.

Fault	Cause	Troubleshooting
Plasma device does not ignite.	Insufficient ground connection to the source of cutting current.	▶ Check the ground cable of the plasma device.
	Coating of the product support (especially in new condition) insulated against the plate to be cut.	▶ Scrape paint off the supports using a steel plate or grind it off using a roughing disc or twisted knot brush.
Paint burns on the outside of the product.	Too high cutting capacity.	▶ Check the set power range.
	The plate is positioned with the cutting edge too close to the outer edge of the product.	▶ Check the position of the plate to be cut in relation to the outer edge.
	A phase cut outward heats up the product's outer plate.	▶ Observe a sufficient distance outward during phase cutting.

Table 4 Faults and troubleshooting

12 Disassembly

⚠ WARNING



Risk of injury due to sharp edges

The edges of the cutting grid are very sharp. Cutting injuries can be the result.

- ▶ Wear protective gloves.
- ▶ Use at least 2 people for removal and insertion of the cutting grid.

1. Remove both potential equalization cables.

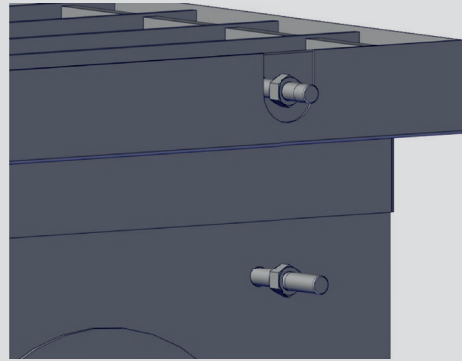

2. Disassemble the filter system piping at the product connection piece.

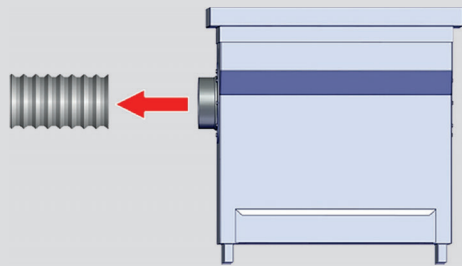

3. Pull the dust collecting container out.

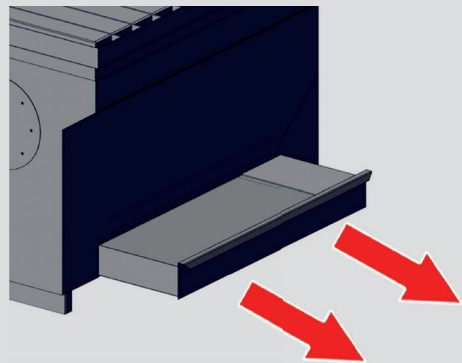

4. Have 2 people carefully lift and remove the cutting grid.

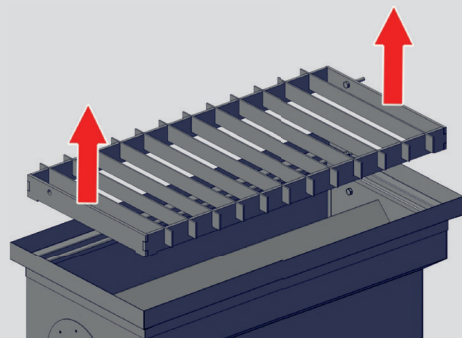

13 Disposal

13.1 Disposing of Cutting and Welding Dust

The disposal of cutting and welding dust and slag is subject to special waste regulations. Cutting and welding dust and slag must not be allowed to get into the sewage system or be disposed of together with household waste.

- ▶ Heed local laws and directives on disposal.

13.2 Disposal of materials

This product is mainly made of metallic materials that can be melted in steel and iron works and are thus almost infinitely recyclable. The plastic materials used are labeled in preparation for their sorting and separation for later recycling.

- ▶ Heed local laws and directives on disposal.

13.3 Disposal of consumables

Oil, greases and cleaning agents must not contaminate the ground or enter the sewage system.

- ▶ Store, transport and dispose of consumables in suitable containers.
- ▶ Dispose of contaminated cleaning tools (brushes, rags, etc.) in accordance with the information provided by the consumables' manufacturer.
- ▶ Observe the local laws and regulations on disposal provisions in the safety data sheets of the consumables manufacturer.

13.4 Disposing of packaging

THERMACUT has reduced the transport packaging to a minimum. The ability to recycle packaging materials was always considered during their selection.

- ▶ Heed local laws and directives on disposal.

14 Addresses and contacts

EUROPE

CZECH REPUBLIC

THERMACUT, k.s.
Headquarters and Production
Sokolovská 574, Mařatice
686 01, Uherské Hradiště
Tel.: +420 572 420 411
Fax: +420 572 420 420
IČ: 46963715 / DIČ: CZ46963715
Email: info@thermacut.cz
reditelstvi@thermacut.cz
www.thermacut.cz

THERMACUT, k.s.
Central Sales Department
Dukelská 76A
742 42 Šenov u Nového Jičína
Tel.: +420 556 423 418, 440
Email: sales@thermacut.cz
obchod@thermacut.cz
www.thermacut.cz

GERMANY

THERMACUT GmbH
Am Rübgarten 2
D-57299 Burbach
Tel.: +49 (0)2736 29 49 11-0
Fax: +49 (0)2736 29 49 11-77
Email: info@thermacut.de
www.thermacut.de

CROATIA

THERMACUT CROATIA d.o.o.
Petra Preradovića 21
532 70 Senj
Tel.: +385 53 882 622
Email: thermacut@gs.t-com.hr
www.thermacut.hr

POLAND

THERMACUT-POLAND SP. Z O.O.
ul. Stawowa 20
43-400 Cieszyn
Tel.: +48 33 852 13 34
Email: thermacut@thermacut.pl
www.thermacut.pl

FRANCE

THERMACUT FRANCE
6 Rue des Frères Lumière
67201 Eckbolsheim
Tel.: +33 3 88 76 58 75
Email: thermacut@thermacut.fr
www.thermacut.net

ROMANIA

THERMACUT ROMANIA SRL
B-dul 1 Decembrie 1918
no. 127A
540445 Târgu Mureş,
Jud. Mureş
Tel.: +40 265 263 205
Fax: +40 265 250 317
Email: office@thermacut.ro
www.thermacut.ro

UKRAINE

ООО "Термакат Украина ГмбХ"
ул. Петропавловская 24
С. ПЕТРОПАВЛОВСКАЯ БОРЩАГОВКА
КИЕВО-СВЯТОШИНСКИЙ Р-Н 08130
Тел./факс: +380 44 403 16 99
+380 50 336 33 91
Email: info@thermacut.ua
www.thermacut.ua

GREAT BRITAIN

Abicor Binzel UK Ltd.
Binzel House,
Mill Lane
Winwick Quay
Warrington,
WA2 8UA, Cheshire
Tel.: +44 1925 653944
Fax: +44 1925 654861
Email: info@abimail.co.uk
www.thermacut.net

SWEDEN

Alexander Binzel AB
Ringugnsgatan 4
SE-216 16 Limhamn
Tel.: 0046-40 6 991 750
Fax: 0046-40 6 991 770
Email: order@binzel.se
www.thermacut.net

DENMARK

Abicor Binzel A/S Denmark
Ringugnsgatan 4
SE-216 16 Limhamn
Tel.: 0045-43621633
Fax: 0045-43622324
Email: ac@binzel.se,
ket@binzel.se
www.thermacut.net

SLOVAKIA

THERMACUT SLOVAKIA, s.r.o.
Priemyselná ulica 1239
931 01 Šamorín
Tel.: +421 31 591 0121
+421 903 644 954
Email: obchod@thermacut.sk
www.thermacut.sk

NORWAY

Binzel Norge AS
Industrieveien 6
N-3300 Hokksund
Tel.: 0047-32 25 19 90
Email: post@binzel.no
www.thermacut.net

FINLAND

ABICOR BINZEL Finland Oy
Kartanontie 53
28430 Pori
Tel.: +358 2 634 4600
Fax.: +358 2 634 4650
Email: info@binzel.fi
www.thermacut.net

HUNGARY

COOPTIM HEGESZTÉSTECHNIKA Kft.
2030 ÉRD,
BUDAFOKI ÚT 10.
Tel: +36 (23) 521 430
Email: aruhaz@cooptim.hu
www.thermacut.hu

ASIA

TURKEY

ABICOR BINZEL Kaynak Teknik
Ticaret LTD. STI.
Girne Mah. Irmak Sok. Küçükyali iş
Merkezi E Blok No: 72-6E PK: 34852
Maltepe Istanbul Türkiye
Tel.: +90 (216) 367 90 00
Fax: +90 (216) 367 90 14
Email: satisdestek@binzelabicor.com.tr
www.thermacuttr.com

KAZAKHSTAN

ABICOR BINZEL CENTRAL ASIA
АЛМАТЫ
УЛ. ЕГИЗБАЕВА 52, 050046.
Тел.: + 7 777 826 42 42
+ 7 717 262 57 30
Email: info@thermacut.com.kz
www.thermacut.kz

SOUTH KOREA

Abicor Binzel Korea Ltd.
#A-101, 263, Gaejwa-ro
Guemjeong-gu
Busan
Tel.: 0082 (31) 732 6065 / 6066 / 6067
Fax: 0082 (31) 732 6064
Email: don.kim@binzel.kr
www.thermacut.net

UNITED ARAB EMIRATES

ABICOR BINZEL MIDDLE EAST FZE
PO Box: 86026, WFZ-04/27 RAKIA Freezone,
Jazeera al Hamra
Ras al Kaimah, United Arab Emirates

INDIA

ABICOR BINZEL TECHNOWELD PVT LTD
SNo: 297, Indo German Technology park
Village: Urawade
Taluka: Mulshi
District: Pune-412 115
Tel.: 020-66743914, 020-39502691
Email: commercial@abicor-india.com
www.thermacut.net

VIETNAM

MNT Industries Vietnam Co Ltd
No. 17, Street 34, Binh Tri Dong B Ward,
Binh Tan District; Hochiminh City
Tel.: 0084-903 858 001
Email: ezio.minh@mnt.com.vn
www.thermacut.net

JAPAN

Thermacut Japan Ltd.
3F Shin-Osaka Hankyu Building
1-1-1, Miyahara, Yodogawa-ku, Osaka
532-0003 Japan
Mobil: +81 (0)80 4738 9752
Tel.: +81 (0)6 7662 8857
Fax: +81 (0)6 7635 7498
Email: s.miura@thermacut.jp

Tel.: +971 (7) 2432355
+971 50 377 1348
Fax: +971 (7) 2432356
Email: info@binzel-abicor.ae
www.thermacut.ae



THERMACUT[®]
THE CUTTING COMPANY[®]

© Copyright Thermacut k.s, Subject to change without a notice. All Rights Reserved.